



SHF Communication Technologies AG

Wilhelm-von-Siemens-Str. 23D • 12277 Berlin • Germany

Phone ++49 30 / 772 05 10 • Fax ++49 30 / 753 10 78

E-Mail: sales@shf.de • Web: <http://www.shf.de>

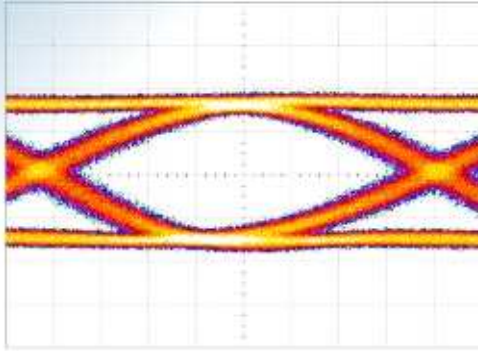

Application Note

Upgrading 12.5 G BERTs to 50 Gbps





The purpose of this application note is to describe how an existing 10 or 12.5 Gbps bit error tester can be upgraded to 40 or 50 Gbps.

The necessary equipment such as multiplexers, demultiplexers and accessories are described and several solutions for an upgrade are presented and compared.

For using those modules you need the SHF 10000A/B mainframe which acts as power supply and control unit for all included plug in modules.

Multiplexer



The most important instrument to upgrade a pattern generator to 50 Gbps is the multiplexer **SHF 24210A**.

The SHF 24210A is a broadband unit supporting **data rates from 2 to 60 Gbps**.

A single master clock signal of half the output data rate is used to drive the multiplexer. The clock/2 output (1/4 bit rate) supports perfect synchronization of a 15 Gbps pattern generator. To align the phase of the clock with respect to the input data, an automatic controlled delay line is installed inside the instrument.

The data output signals offer outstanding signal quality in terms of jitter, S/N ratio and eye opening and facilitate easy testing of ultra high speed components and their assembly into complex communication systems.

The output stage of the instrument is individually optimized for superior pulse performance at the end of a 0.5 m low loss, high precision 50 GHz cable assembly, which is provided with the instrument.

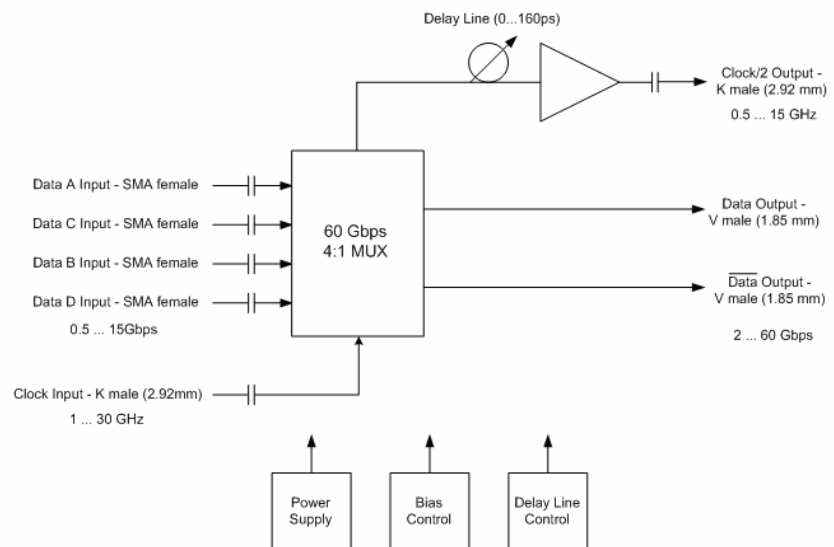



Demultiplexer

To upgrade the error analyzer our demultiplexer, the **SHF 34210A** is recommended. The SHF 34210A also covers a **wide range of data rates: 2 to 60 Gbps**. The key performance parameters are: **Sensitivity** (better than 50 mV below 50 Gbps) and **clock-phase margin** (better than 200° below 50 Gbps).

Like the SHF 24210A it **operates with half clock** – so you do not need a 50 GHz clock source. The SHF 34210 A also offers a **clock/2 output** making the clock distribution in your measurement setup easy.

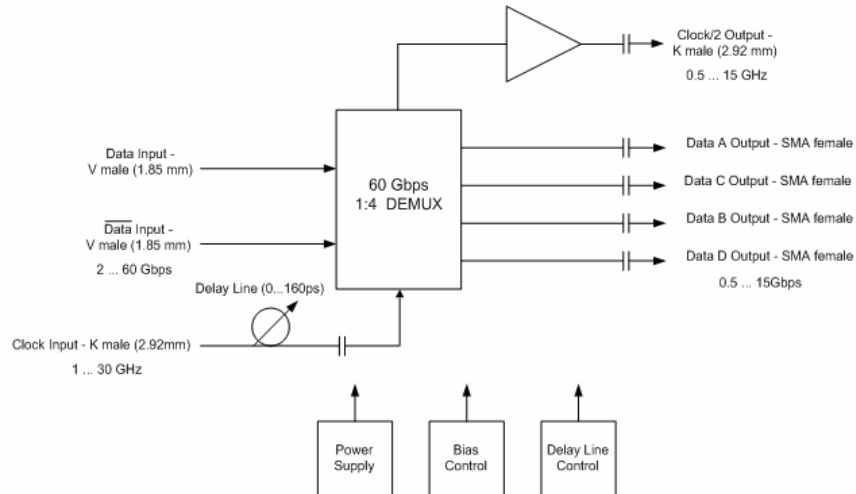

Signal Splitter and signal selector

If a single channel pattern generator is being upgraded, you need a further device to split the signal into four different paths. The **SHF 58210A Option SP** is a suitable choice.

The SHF 58210A Option SP is mainly designed for splitting and de-correlating one data stream up to 15 Gbps into four quasi independent data streams at the same bit rate. The incoming signal is divided into four channels. Each of the four channels is delayed by a different value in order to provide sufficient de-correlation of the output signals.

The SHF 58210A is preset for **true PRBS 2⁷-1 @ 9.953 Gbps** but is suitable for bit rates up to 15 Gbps and a pattern length of 2³¹-1. Multiplexing in these cases will not give you true PRBS but as the four paths are decorrelated by the delays you will get a “Quasi” PRBS. For fine adjustments, a 160ps computer controlled adjustable delay line is implemented in each channel.

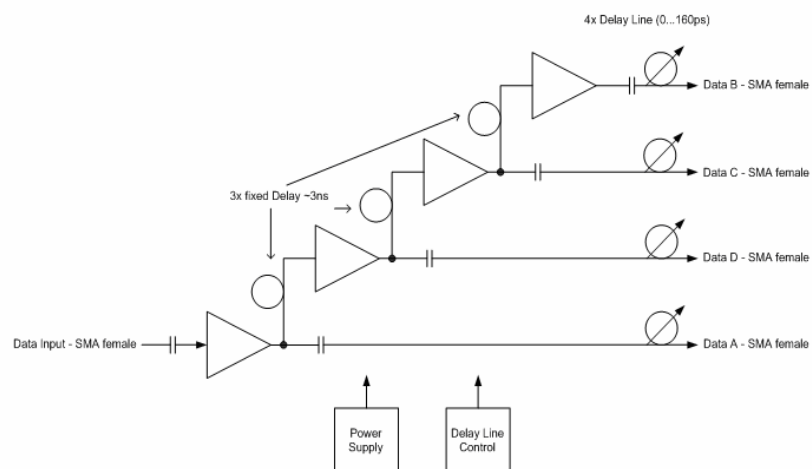



If you have a single channel error analyzer, you have to either assume that the errors are distributed evenly in all four channels or you need to measure all four sub-rates sequentially. In order to make this easier, we offer the **SHF58210A Option SE**, which is basically a computer controlled switch.

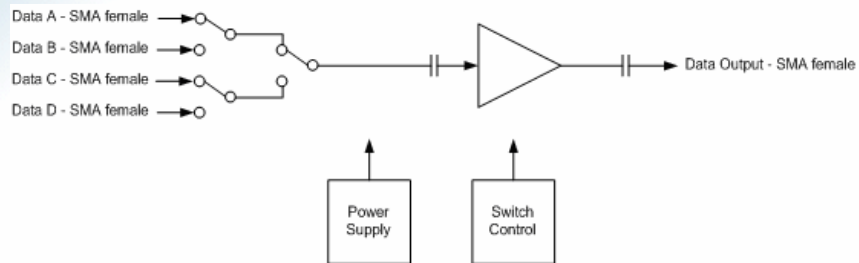

The module SHF58210A can be equipped with both or with only one of the two functional blocks (Signal Splitter *SP* and Signal Selector *SE*). Extra flexibility and cost efficiency are the benefits for the customer.

Frequency Doubler

As mentioned, you need a clock source supporting 25 GHz if you upgrade to 50 Gbps. The best choice is to have an appropriate synthesizer. As the 34210A and the 24210A have broadband frequency dividers you will get a broadband system. Unfortunately sometimes another parameter is of concern: The budget. If your existing BERT only has a clock source covering 10 GHz and if you can not afford a new clock source, a frequency doubler (SHF 1020B) is an alternative. Bear in mind though that a frequency doubler is narrow band: 9 to 11 GHz gives an output frequency of 18 to 22 GHz which translates to 36 to 44 Gbps.

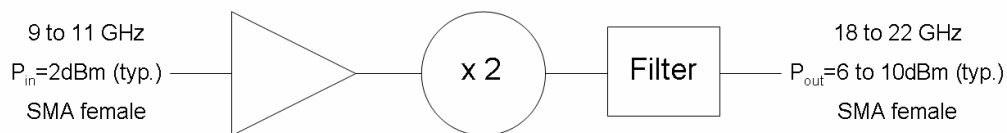



Set Up`s

Set up with 10 GHz clock source

This is the setup with a 10 GHz clock source:

Please note that the frequency doubler has an output power of typical +6 to +10 dBm, the power divider SHF AT27 has an insertion loss of 6 dB and the optimum clock input level of the mux and demux is between 0 and +4 dBm.

If you upgrade only the generator side you would not need the power divider, in this case please make sure that the output of the doubler is attenuated to match the required clock input level of the multiplexer!

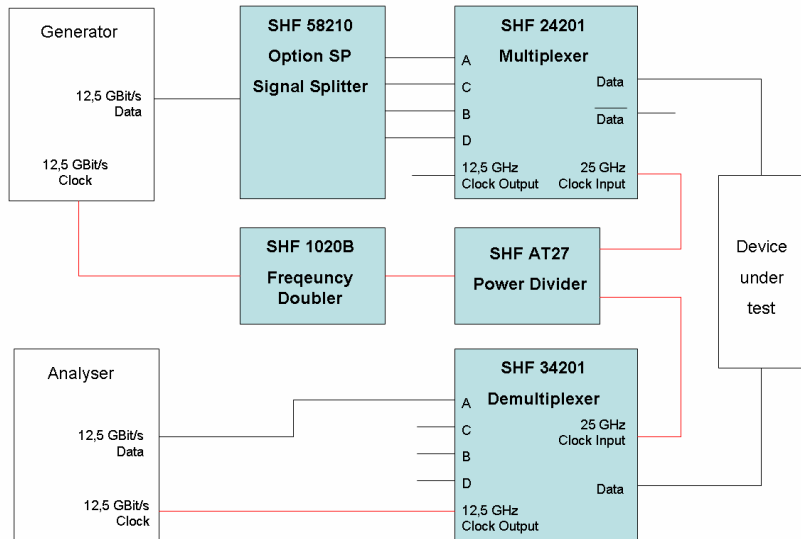

If your device under test has several meters of fiber, you will need a clock recovery such as the SHF 41210B Option CR or SHF 11120C at the demultiplexer, using the same clock for multiplexer and demultiplexer will not work due to the jitter and phase walk off caused by the fiber.

Set up with 25 GHz synthesizer

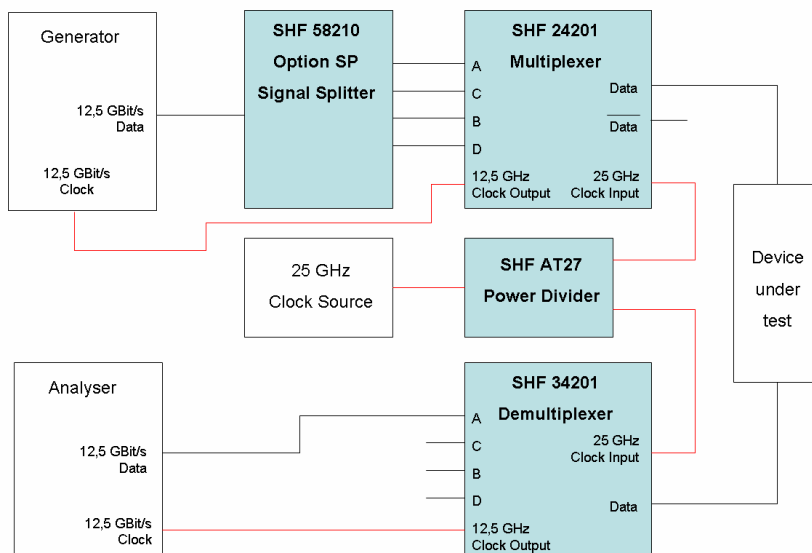

If you have a 25 GHz synthesizer, this will be the setup.

As we do not need the doubler any more we now can take full advantage of the broadband data rates of the SHF 24210A and 34210A.

Again, the 41210B Option CR clock recovery would be needed if the DUT has long optical fibers.



Set up with tributary data selector SHF 58210A Option SE

In order to measure all four sub-rates we recommend the data selector SHF 58210A Option SE, which will allow you to sequentially measure all four outputs by computer control.

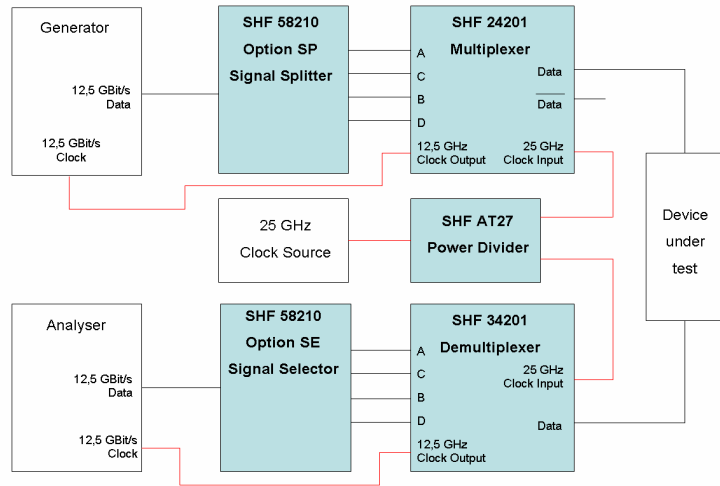

Set up with 4- Channel BERT

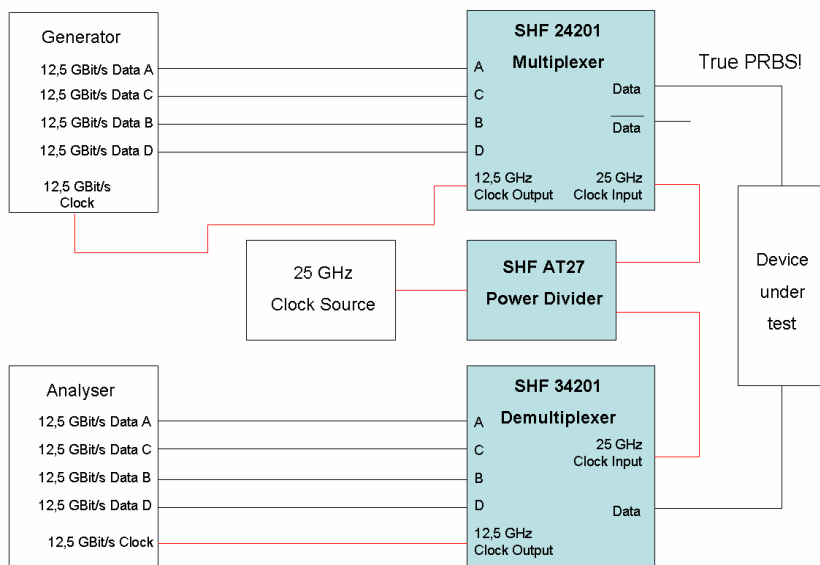

If you already have a four channel BERT system, the upgrade will be easier: you do not need the signal splitter and the data selector.

This approach also allows you to generate true PRBS if the four outputs are PRBS/4 shifted. For many applications true PRBS is not important, but if you have to test according to standards prescribing true PRBS you have only two choices: either a 44 Gbps BERT system or to upgrade a 12 Gbps, four channel system.



It should be mentioned that SHF does not only offer instruments, but also modules: The SHF 404 multiplexer and the SHF 423 demultiplexer. These modules are intended for fast prototyping, but they can also be used as a very cost effective solution to upgrade an existing BERT System. Of course the modules do not have the ease of use that our instruments offer: You will need additional hardware like delay lines and computer controlled measurements would require additional effort.

Nevertheless these modules can be used as a very cost effective way to upgrade a system and as the module has 1.85 mm connectors, it can handle many connections without degradation.



True PRBS versus Quasi PRBS

For the generation of true PRBS at very high bit rates multiplexing is necessary. For a 4:1 multiplexer the output signal will be again true PRBS if the input patterns are shifted by PRBS/4. In a pattern generator the four PRBS sub-rates can be digitally delayed by entering the appropriate start sequence in the individual shift registers – therefore the pattern generator gives you true PRBS.

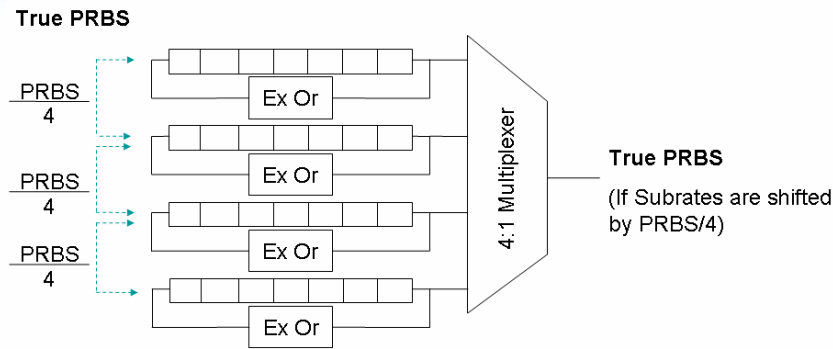

In the SHF 58210A Option SP signal splitter the delay to de-correlate the four sub-rates is done by cables – consequently (if the device is not used with PRBS 2^7-1 @ 4 x 9.953 Gbps) the output signal will not be true PRBS, it will be a Quasi PRBS sequence.

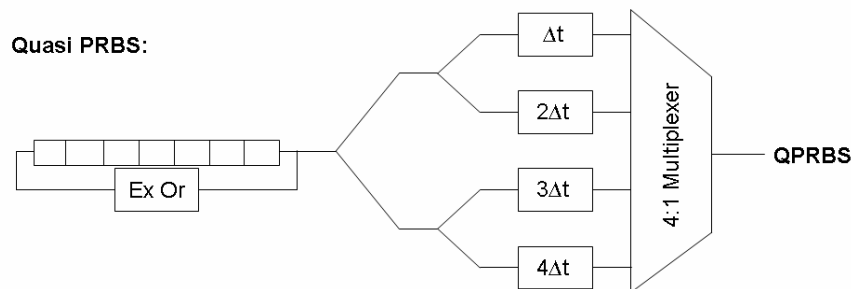

Let's have a closer look at the difference between true and quasi PRBS:

If the sub-rates are reasonably de-correlated the envelope of the spectrum will be very similar to the envelope of a true PRBS sequence: The QPRBS spectrum will exhibit a similarly smooth $\sin(x) / x$ envelope.

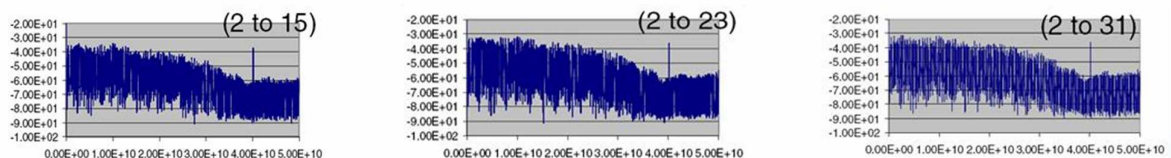

- Spectrum of QPRBS Signals with a length of $2^{15}-1$ (left), $2^{23}-1$ (right) and $2^{31}-1$ (right) -



If you take a closer look to the spectrum you will observe that the spectral lines of the QPRBS are four times denser.

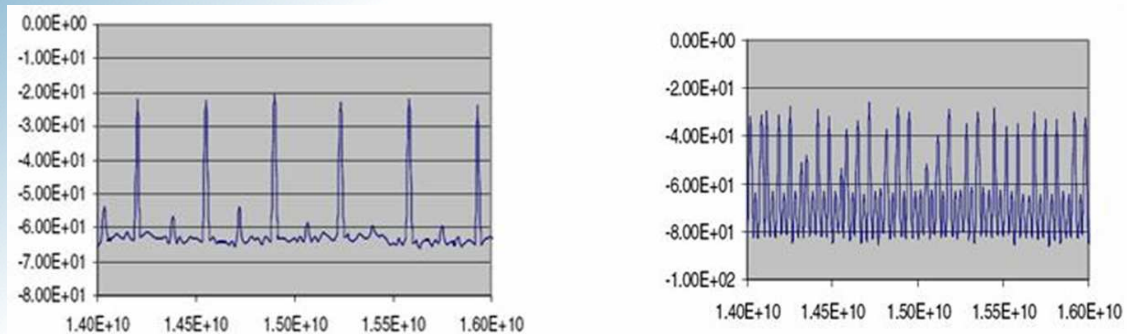

- Spectrum of a 44 Gbit/s PRBS Signal (2^7-1) (left) compared to a 40Gbit/s QPRBS ($4 \times 10\text{Gbit/s PRBS } 2^7-1$) (right) -

For a true PRBS pattern, the spacing is: Data Rate / $(2N-1)$. As the QPRBS spectrum is denser it is actually a more stringent test (similar to a group delay measurement: the smaller the aperture the more stringent the test).

An important feature of PRBS sequences is that they have long runs of consecutive ones and consecutive zeros. Also QPRBS offers this feature, single ones and zeros are present as well as long runs of consecutive ones and consecutive zeros – this is the reason why the spectral envelope is similar and this is also the reason why you do not see any difference in the eye diagrams of true PRBS and QPRBS signals.

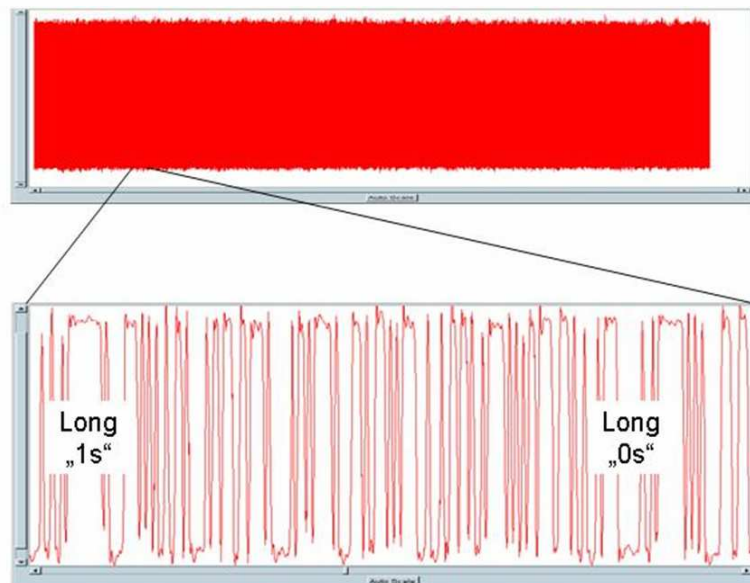

QPRBS and novel modulation schemes

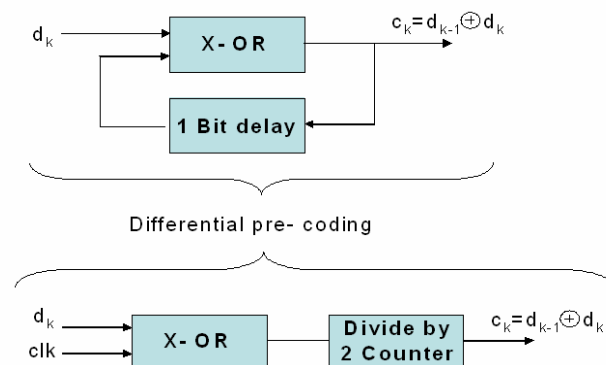

If you will be using your BERT system to generate and analyze optical DPSK or duobinary signals you might want to consider a 50 Gbps pattern generator: As DPSK and duobinary transmission requires precoding you would need a precoder if your test signal would be QPRBS.

True PRBS signals do not need a precoder, as the precoder would only delay the true PRBS sequence.



Conclusion

- For experiments with DPSK and duobinary modulation schemes true PRBS is more convenient, as precoding is not necessary
- If test has to be performed according to CCITT PRBS is the only choice
- + Both PRBS and Quasi- PRBS patterns exhibit smooth $\sin(x)/x$ spectral response
- + The Quasi PRBS pattern appears 4 times the pattern length of the equivalent PRBS data – Spectral spacing of Quasi PRBS is 4 times denser
- + Explore the spectral characteristics of the device or subsystem under test
- + A more sensitive test than standard PRBS pattern
- + Quasi- PRBS pattern is as good as, and better than PRBS in some aspects