



SHF Communication Technologies AG

Wilhelm-von-Siemens-Str. 23D • 12277 Berlin • Germany

Phone ++49 30 / 772 05 10 • Fax ++49 30 / 753 10 78

E-Mail: sales@shf.de • Web: <http://www.shf.de>

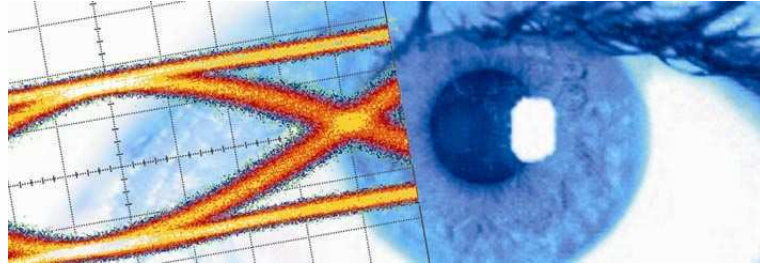

Datasheet

SHF 41210B

Clock Recovery Optical Receiver





Description

The SHF 41210B is an optical receiver and clock recovery unit. This plug-in module is part of the SHF modular measurement series and needs to be installed in a mainframe type SHF 10001A or SHF 10000B. Together with other plug-in modules from this instrument series, a modular and scalable measurement system can be configured. Field installation or upgrade by the end-user is possible for this part of equipment. It can be specified as just a receiver (option OE), or just clock recovery (option CR) or with both options. Both options are separate building blocks, they are connected internally!

The optical receiver converts optical signals with a bit rate up to 50 Gbps into electrical signals. The wide output dynamic range combined with excellent pulse behavior makes the device ideal for optical system research.

The Clock Recovery is designed to extract and synchronize the clock from a serial data stream. It operates at bit rates from 39.8 to 43.1 Gbps.

It uses two separate VCOs which allow operation in two bands. The lower band spans the range between 39.8 and 41.6 Gbps and the higher band spans the range between 41.6 and 43.1 Gbps.

Due to the circuit concept a reference clock with a frequency of bit rate divided by 64, 32 or 16 must be applied to the unit. For better convenience reference oscillators for three standard bit rates (39.813 Gbps, 42.656 Gbps and 43.018 Gbps) are built-in.

The clock recovery also operates at data rates around 20 and 10 Gbps ($\frac{1}{2}$ and $\frac{1}{4}$ of the nominal bit rate). However, the clock output will give a signal proportional to the nominal bit rate.

The SHF 11120C can be operated remotely via Ethernet-connection from a PC running the SHF BERT Control Center control software (BCC). Its programming features allow automated measurements using test programs like Agilent VEE or National Instruments LabView.

Features

Optical Receiver

- Broadband operation up to 50 Gbps
- High optical sensitivity
- Wide output dynamic range
- High output saturation suitable for 2R regeneration
- Excellent pulse behavior
- Unsurpassed high power handling capability
- High responsivity

Clock Recovery

- Operating bit rate range from 39.8 to 43.1 Gbps (this includes OC-768 with and without FEC)
- Clock output frequency at half and quarter of the nominal input data bit rate
- Excellent input sensitivity of 50 mV

Options

- Option OE: With optical/electrical converter
- Option CR: With clock recovery
- Option C40: Full clock output



Block Diagram

Optical Receiver

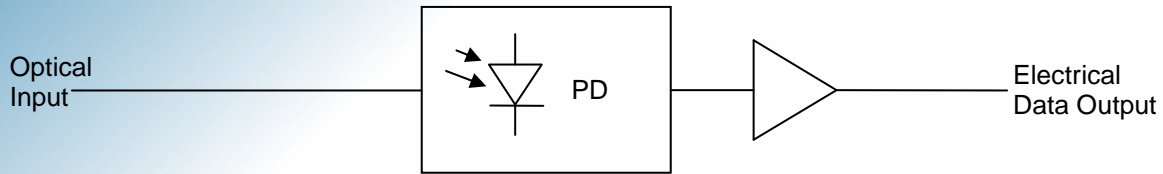

Clock Recovery

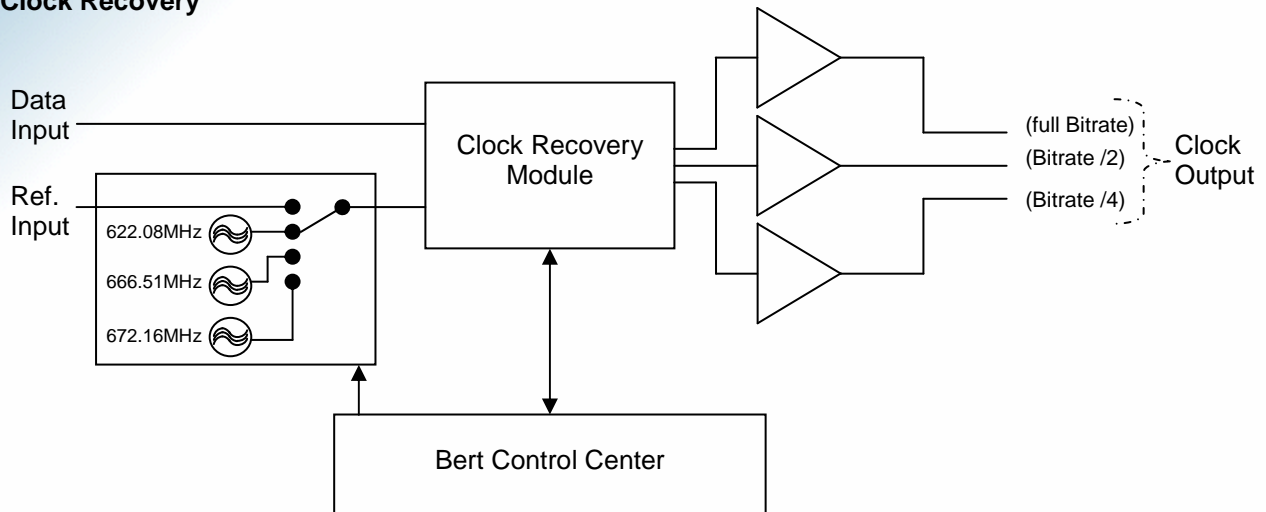

Specifications – SHF 41210B

Option CR – Clock recovery

Parameter	Unit	Min.	Typ.	Max.	Comment
Data Input					
Operating bit rate	Gbps				
VCO1		39.8		41.6	
VCO2		41.6		43.1	
Locking Range ¹	MHz		± 4		
Input Voltage	mV	50		800	
Connector	Ω		50		ruggedized V-male
Return loss	dB		8		
Reference Clock Input					
Input Frequency	GHz				
(Bit Rate / 64 mode)		0.622		0.674	
(Bit Rate / 32 mode)		1.244		1.348	
(Bit Rate / 16 mode)		2.488		2.696	
Input Voltage	mV _{pp}	400		800	
Connector	Ω		50		SMA-female

¹ PRBS 2³¹-1, Input Amplitude 100mV



Parameter	Unit	Min.	Typ.	Max.	Comment
Internal Reference Clock					
Clock 1	MHz		622.080		39.81312 Gbps
Clock 2	MHz		666.514		42.65692 Gbps
Clock 3	MHz		672.163		43.01841 Gbps
Clock /4 Output (quarter bit rate)					
Output Frequency	GHz	9.95		10.775	
Output Voltage	mV _{pp}	400		600	
Connector	Ω		50		SMA- female
RMS-Jitter	fs		550	700	Note 1
Half Clock Output (half bit rate)					
Output Frequency	GHz	19.9		21.55	
Output Voltage	mV _{pp}	500		1000	
Connector	Ω		50		ruggedized K-male
RMS-Jitter	fs		450	600	Note 1
Full Clock Output (optional, full bit rate)					
Output Frequency	GHz	39.8		43.1	
Output Voltage	mV _{pp}	500		1000	
Connector	Ω		50		ruggedized V-male
RMS-Jitter ²	fs		450	600	

Option OE – Optical receiver

Parameter	Unit	Min.	Typ.	Max.	Comment
Wavelength range		C and L band			
High frequency 3dB point	GHz	30			
Low frequency 3dB point	kHz			30	
Conversion gain	mV/mW	350	450		at 1550 nm
Receiver sensitivity	dBm		-9		
Output saturation voltage (peak-peak)	V		5	6	
Rise/fall times	ps		9	10	10...90%
Optical input power	dBm			13	CW
Data Out Connector	Ω		50		ruggedized V-male
Optical Connector ³			FC/PC		

² on scope display, measured with Agilent 86100A with precision time base

³ Consult SHF for other requests



Test Results

Option CR – Clock recovery

Test Results @39.813 Gbps with Internal Reference 1 (622.08 MHz)

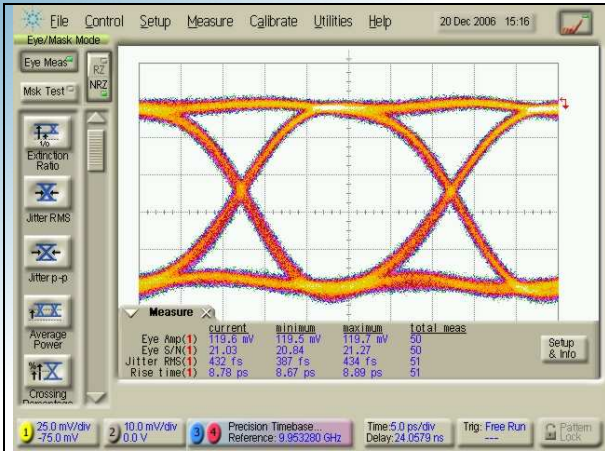

Data In @ 39.813 Gbps

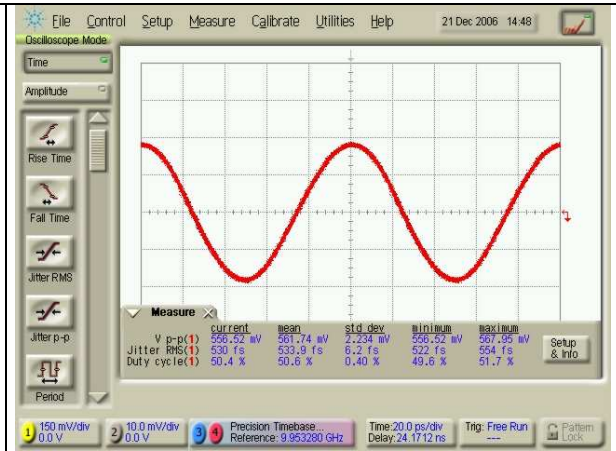

Clk/4 Out @ 39.813 Gbps

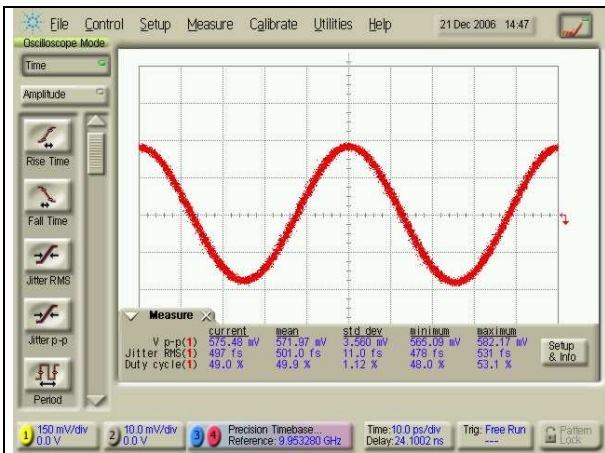

Clk/2 Out @ 39.813 Gbps

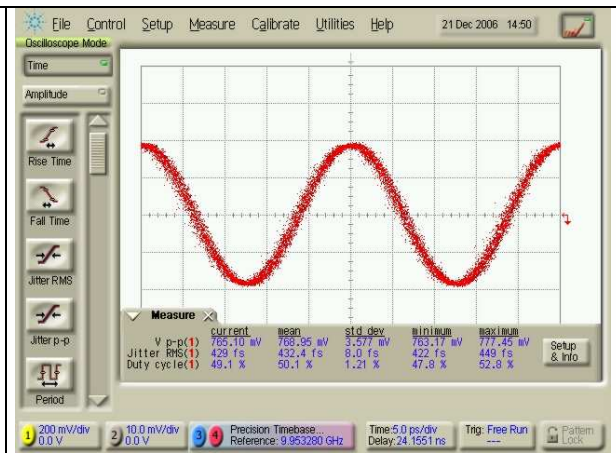

Clk Out @ 39.813 Gbps



Test Results @ 42.656 Gbps with Internal Reference 2 (655.514 MHz)

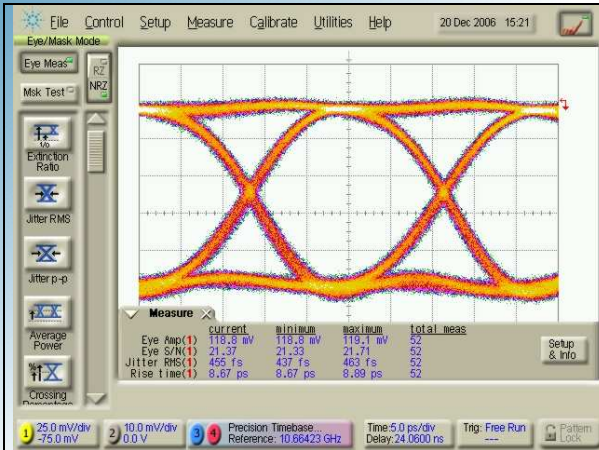

Data In @ 42.656 Gbps

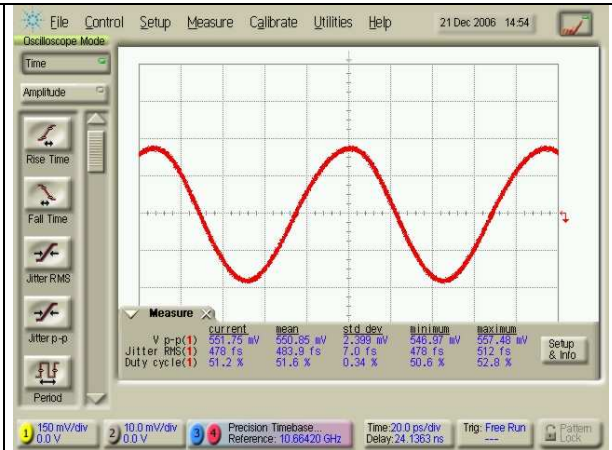

Clk/4 Out @ 42.656 Gbps

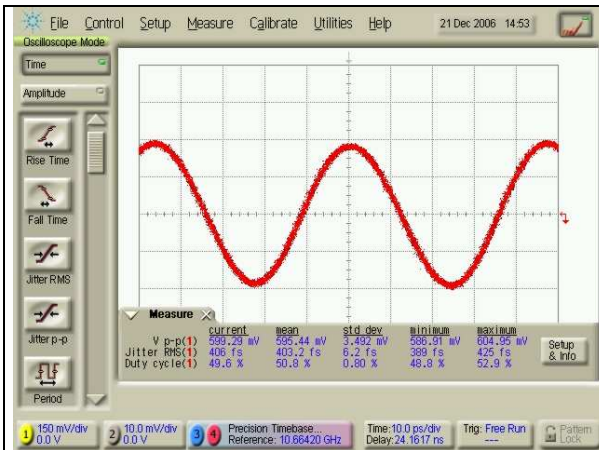

Clk/2 Out @ 42.656 Gbps

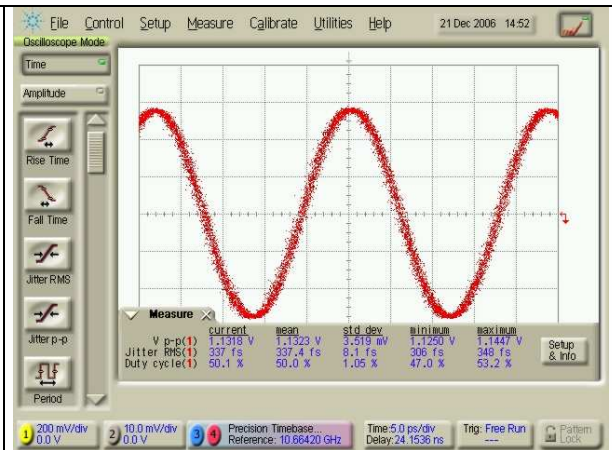

Clk Out @ 42.656 Gbps



Test Results @ 43.018 Gbps with Internal Reference 1 (672.163 MHz)

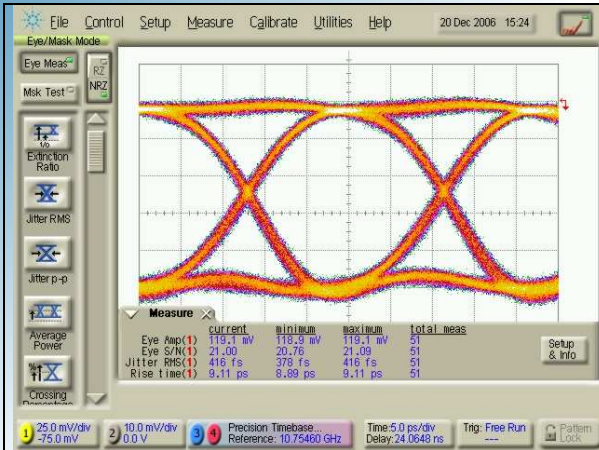

Data In @ 43.018 Gbps

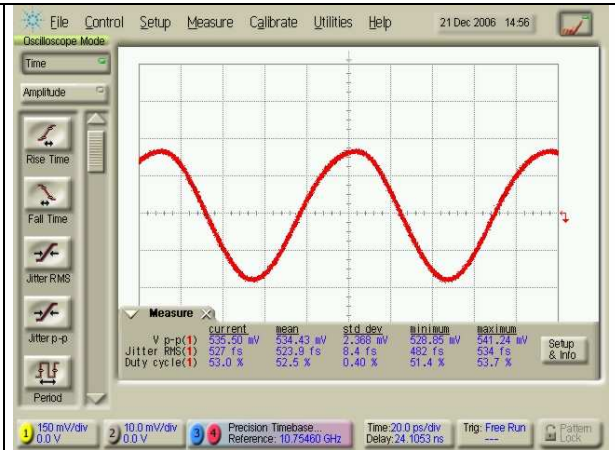

Clk/4 Out @ 43.018 Gbps

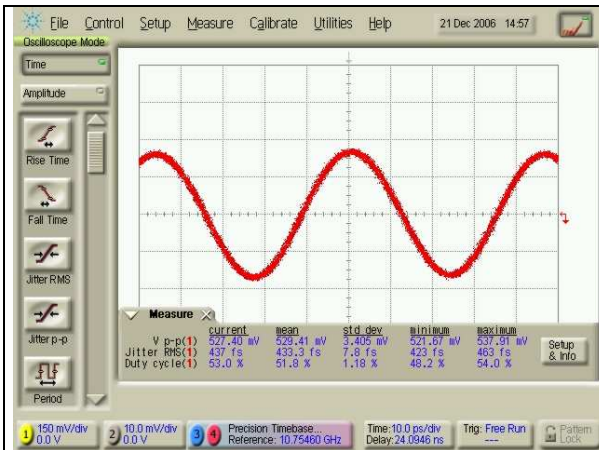

Clk/2 Out @ 43.018 Gbps

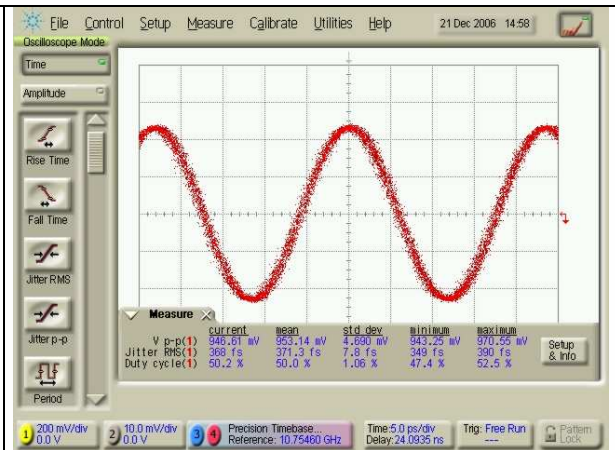

Clk Out @ 43.018 Gbps