

VME4SSI

Shaft-Angle Encoder Interface VME-Board

Content

1 General	3
2 Functional Description	3
2.1 Board Addressing.....	3
2.1.1 Base Address for VMEbus Subrack.....	3
2.2 Address Modifier.....	3
2.3 SSI Interfaces.....	4
2.4 Possible Transducers.....	5
2.5 SSI Data Transmission.....	6
2.6 Position Detection.....	7
2.7 Function Register.....	8
2.8 Functional Control of the VME4SSI.....	9
3 Dialog Registers	10
3.1 Command Register.....	11
3.2 Acknowledgement Register.....	11
3.3 Status Register.....	11
3.4 Data Dialog Registers.....	12
4 Connector Layout	13
4.1 Connection Information.....	16
5 Technical Specifications	17

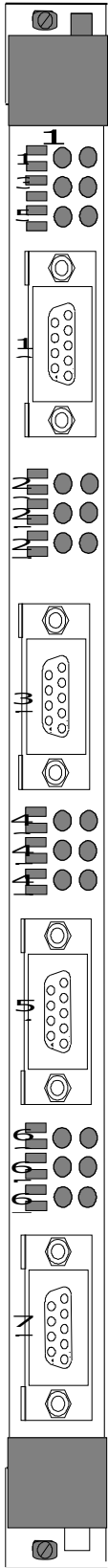

1 General

The VME4SSI input board measures the positions of up to four absolute transducers with an SSI interface (synchronous-serial interface). Single-turn, multi-turn shaft angle encoders and linear transducers - each with Gray or binary code - can be connected. The board does the necessary conversion from the Gray to the binary code. The front panel is fitted with the connector plugs for the shaft angle encoders and/or linear transducers and sockets, as well as LEDs for indicating the signal states. The VME4SSI is a plug-in-type VMEbus board of double Euroformat standard size (6 HEs - height units) with a width of 4 TE divisions

2 Functional Description

The board has 4 SSI channels (synchronous-serial data transmission from the transducer) with the clock pulse generators and data inputs allocated to the interfaces. All the channels are potential-isolated against each other and against the VMEbus. Each of the four channels measures and processes the position transmitted by the shaft-angle encoder or linear transducer, resp. In this context, conversion of Gray to binary code and evaluation of an optional transducer monitoring function (e.g. PFB power fail bit) are possible. The shaft-angle encoders and linear transducers are connected via 9-pin DSUB connectors on the front panel.

2.1 Board Addressing

The board has a VMEbus slave interface and uses an address area of 1 kByte in the A24:D16 address area. It is designed for use in standard VMEbus subracks. BERR* is output in the case of an access to the VME4SSI with A24:D16 and LWORD* active.

2.1.1 Base Address for VMEbus Subrack

The slot (location) address for generating the base address can be set on the VME4SSI internally on the VME4SSI by means of DIP switch S1 and S2.

The default basic address is E41000h

Setting the slot (location) address:

S2.8	S2.7	S2.6	S2.5	S2.4	S2.3	S2.2	S2.1	S1.6	S1.5	S1.4	S1.3	S1.2	S1.1
A23	A22	A21	A20	A19	A18	A17	A16	A15	A14	A13	A12	A11	A10

Position "ON" = 0-signal
 "OFF" = 1-signal

2.2 Address Modifier

The VMESSEI responds to user and supervisor accesses in the A24-range with AM codes (AM0 ... AM5) of 39h or 3Dh.

2.3 SSI Interfaces

The four SSI interfaces for connecting the shaft angle encoders and/or linear transducers have the following structure:

Example: transducer channel 0

VME4SSI

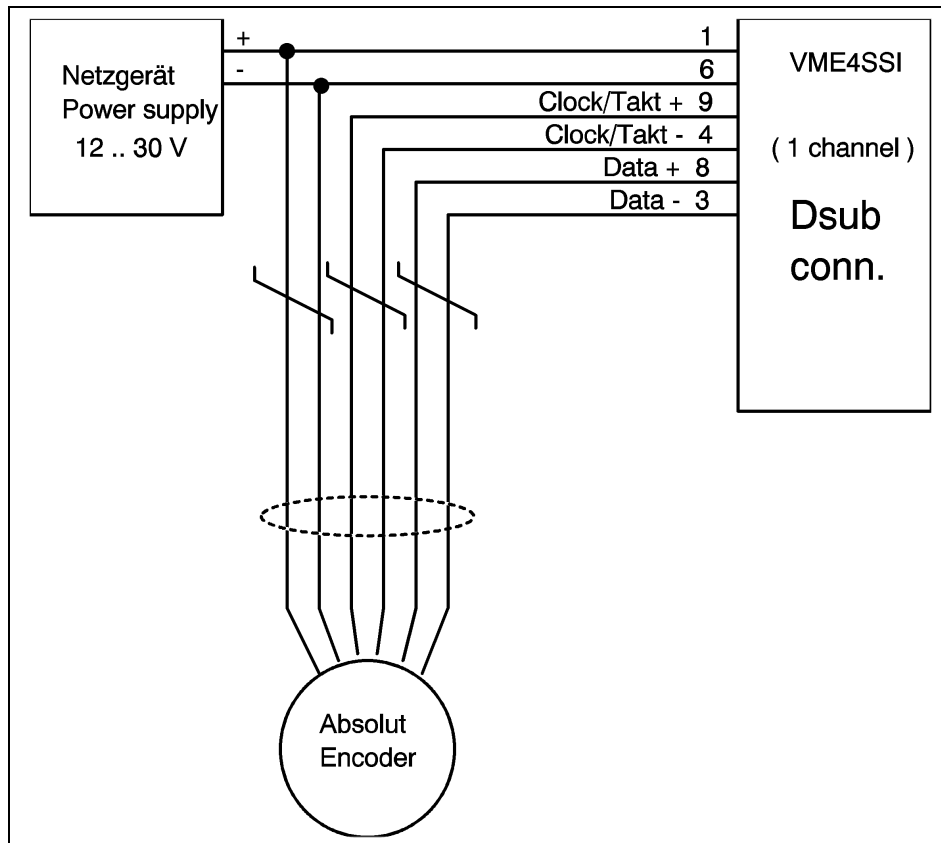

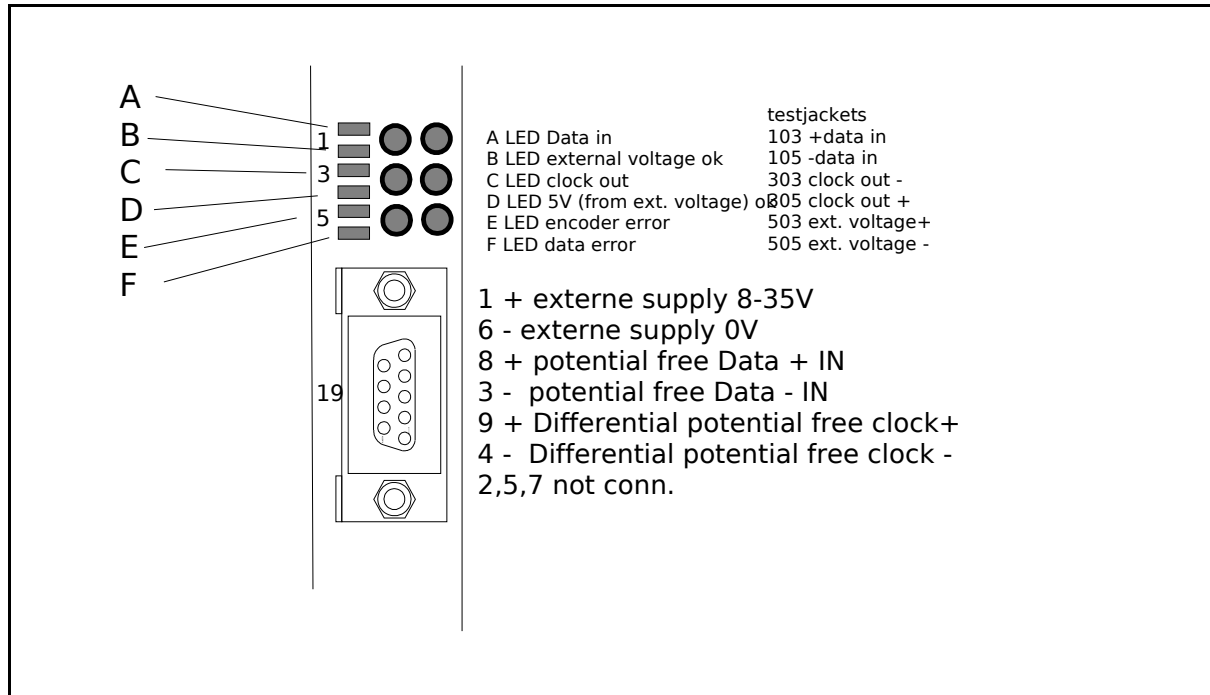

Note: the 24V supply is not needed in the actual VME4SSI boards. Confounding of signal cables can cause loss of information. The measuring sockets on the front panel are connected through a resistor to the measuring signal.

2.4 Possible Transducers

Single-turn, multi-turn shaft angle encoders and linear transducers can be connected to the interfaces of the VME4SSI. Note that the VME4SSI supports only those transducers which transmit a data length of 13 or 25 bits, resp. and which have a certain data format (see para. 2.5). Absolute single-turn shaft angle encoders divide a mechanical revolution (0 to 360°) into a defined number of measuring steps which are repeated after one revolution. The resolution is normally 4096 steps (12 bits) or a maximum of 8192 steps (13 bits) in exceptional cases. Absolute multi-turn shaft angle encoders not only measure the angular position of a revolution, but also discriminate between several revolutions. The resolution is normally 4096 steps per revolution, multiplied by 4096 revolutions (24 bits), or a maximum of 8192 steps, multiplied by 4096 revolutions (25 bits), in exceptional cases.

Linear transducers transmit the absolute position. The precision depends on the length of the measuring distance and the data length of the transducer. Typical transducer resolutions are 12 or 24 bits and, in exceptional cases, 13 or 25 bits, resp.

The VME4SSI supports shaft-angle encoders and linear transducers with binary and Gray code.

Shaft angle encoders and linear transducers transmit a data length of 13 or 25 bits, resp. All the bits are evaluated for identifying the position in exceptional cases only. The least significant bit (D0) is normally available for monitoring purposes only (e.g. PFB power fail bit), or is transmitted as a constant zero.

2.5 SSI Data Transmission

Shaft angle encoders and linear transducers with an SSI interface (synchronous-serial interface) and the data format described herein can be connected to the VME4SSI. The transducer position is supplied as a serial information which is synchronized with a clock pulse (i.e. a defined number of pulses) which is supplied by the VME4SSI. Transmission between transducer and VME4SSI (clock and data as serial position information) takes place via RS 422 interfaces with differential inputs and outputs. All the four transducer interfaces have the same structure and layout - even in terms of their connector layout - so that only one transducer interface is described here. The illustration shows the clock supplied by the VME4SSI and the information (position) supplied by the transducer. Note that the signals are symmetrical (RS 422).

The serial information supplied by the transducer is delayed by the time T_v ($T_v < 300$ ns) in relation to the positive clock edges fed into the transducer. The number of clock pulses supplied depends on the transducer type selected (13 or 25 bits, resp.). After the last clock edge, the "Data +" transducer output changes to a 1-signal after the time t_m ($t_m = 15 \dots 25$ μ s)

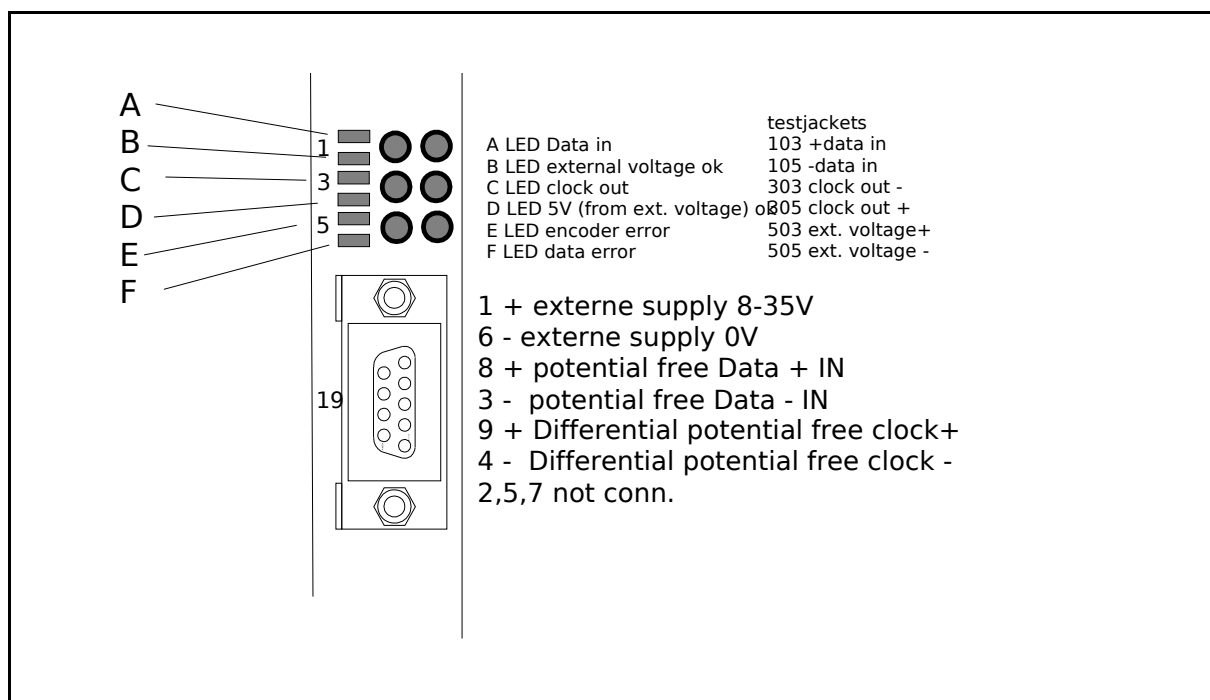

Note: In the case of transducers with an outgoing cable, the shield is usually connected to the enclosure. The VME4SSI can be used to measure the position of transducers transmitting information with a data length of 13 or 25 bits. What is important in this context is that the most significant bit of the information is the first of the bits transmitted by the transducer. The total number (i.e. 13 or 25 bits, resp.) is completely used for the information in exceptional cases only. The transducer normally sends an optional monitoring bit (e.g. PFB power fail bit) or a constant zero as the last data bit.

The information supplied by a linear transducer is at the same time also the absolute position. In the case of a single-turn shaft angle encoder, the position of the transducer within one revolution is reported. In the case of a multi-turn shaft angle encoder, the upper 12 bits represent the number of revolutions, whilst the lower bits correspond to the position of the transducer during the next revolution. The following illustration shows, as an example, the data format of a multi-turn shaft angle encoder supported by the VME4SSI. The resolution of this multi-turn shaft angle encoder totals 4096 revolutions with 4096 steps per revolution (4096 x 4096), and a monitoring bit (PFB power fail bit) is available also. The functionality of the monitoring bit can vary from transducer type to transducer type.

Clock + = Clock pulses supplied by the VME4SSI (valent output)

D0 .. D23 = Information 2⁰ .. 2²³ (Gray or binary code).

PFB = In the event that the actual supply voltage remains below the minimum supply voltage by more than approx. 5V for more than 100µs, the data information from the transducer may be distorted. The power fail bit (PFB) identifies this error by a 1-signal

2.6 Position Detection

All the transducer channels have downstream position registers with an output to the VMEbus.

The position registers have a capacity of 32 bits. The utilization of the registers depends on the transducer type used. The VME4SSI supports transducers which transmit data lengths of 13 and 25 bits, resp. This means that either the data bits D0 to D12 (13 bits) or D0 to D24 (25 bits) are used for information. The remaining bits of the registers have a constant 0.

Contents of the position register of a 13-bit transducer:

D0 D15 **LOW word** D15-D12 =0
D16 D31 **HIGH word** all=0

Contents of the position register of a 25-bit transducer:

D0 D15 **LOW word**
D16 D31 **HIGH word** D31-D25 =0

Note: After receipt of all the data, the information sent by the transducer is loaded into the associated position register. In the case of a simultaneous receipt and reading of the output memory, data inconsistency is possible, particularly in the case of a 25-bit transducer (LOW word and HIGH word belonging to successive data receipts). It is hence recommended reading and comparing the values several times.

The data bits are weighted differently by the different manufacturers. The complete contents of the register are available for the position information in exceptional cases only. The least significant bit normally serves as an optional monitoring bit (e.g. PFB power fail bit), or a constant 0 is assigned to D0. This means that 12 or 24 bits, resp. are available for the position information. What is important is that the most significant bit of the information D12 or D24, resp. is the first of the bits transmitted by the transducer.

2.7 Function Register

For each transducer channel, a separate function register is available in the board. This function register is used for programming the function of the channel. In the event of a change in function, non-plausible output values can temporarily occur in the associated position register.

Clock frequency	D10	D9	D8
1MHz	0	0	0
500KHz	0	0	1
250KHz	0	1	0
125KHz	0	1	1

data length

D11	1	25bits
D11	0	13bit

Transducer PFB

D12	0	no PFB
D12	1	PFB

coding

D13	0	binary
D13	1	Gray-Code

Report Power Fail Bit

D14	0	PFB not send
D14	1	PFB send

Report transducer error

D15 = 0,

Transducer supply available and data output of transducer properly connected.

D15 = 1,

Transducer supply not available, or permanent output of transducer improperly connected to VME4SSI data input.

The contents of D0 to D7 have no function (undefined contents).

D0-D7 no function

Explanation of function register contents:

- Clock frequency (D8 - D10)

The maximum permissible clock frequency mainly depends on the capacity of the cable between transducer and VME4SSI and hence on the length of the cable. In the case of a signal distortion of the transducer information, it must be ensured that the signal change of the transducer information takes place with a lead time of $t > 100\text{ns}$ before the next clock edge. The signal distortion can be measured at the measuring sockets of the VME4SSI. The following table illustrates the relationship between clock frequency and cable length:

Cable length	Clock frequency	Reading time for a 13-bit transducer	Reading time for a 25-bit transducer
< 50 m	1 MHz	< 20 ms	< 30 ms
< 100 m	500 kHz	< 40 ms	< 60 ms
< 200 m	250 kHz	< 80 ms	< 120 ms
< 400 m	125 kHz	< 120 ms	< 240 ms

- Transducer type (D11)
The transducer type (data length 13 or 25 bits) determines the number of clock pulses supplied by the VME4SSI.
- Transducer - power fail bit (PFB) (D12)
In the case of a transducer with a monitoring bit (e.g. PFB power fail bit), the selection of $D12 = 1$ means that the monitoring bit transmitted by the transducer is entered at D14 where it is then available for evaluation purposes.
- Transducer coding (D13)
With $D13 = 1$, the Gray code received is automatically converted to binary code and in this form stored in the position register. With $D13 = 0$, the Gray code received is directly stored in the position register.
 $D13$ must be = 0 if a transducer with binary code is used. In the case of $D13 = 1$, the value stored in the position register is not defined.
- Power fail bit signal (PFB) (D14)
In the case of a transducer with a monitoring bit (e.g. PFB power fail bit) and selection of $D12 = 1$, this bit shows in the event of a PFB whether the supply voltage has remained below the transducer supply voltage by 5V for more than 100 μs , so that distortion of the transducer information is possible.
- Transducer error signal (D15)
This message indicates whether the transducer supply is available and whether the data output of the transducer is properly connected

2.8 Functional Control of the VME4SSI

The following functions can be determined via the command register (see para. 3.1):

-Start bit

After a SYSRESET* or connection of the supply voltage (UB5), the board is not ready for operation during the initialization phase only. Thereafter, the channels can be initialized, and the position registers can be read by the board.

The start bit serves for direct checking as to whether the VME4SSI can be addressed by the central unit.

3 Dialog Registers

The dialog with the VMEbus is handled via these registers, as follows:

Base address	Access	Data size	Remarks
+ 0	read/write	2 Byte	Command register, see para. 3.1
+ 2	read/write	2 Byte	Acknowledgement register, see para. 3.2
+ 4	read only	2 Byte	Status register, see para. 3.3
+ 6	read only	2 Byte	Error code register (0x0), without any function
+ 8	read only	8 char	Identification, basic board type "VME4SSI"
+ 10h	read only	8 char	Identification, Firmware Revision: "Rev 2.5"
+ 18h	read only	8 char	Identification, manufacturer: "SHF AG"
+ 20h – 7Fh	read only	2 char	0
+ 80h	read / write	2 Byte	Function register for channel 0, see para. 2.7
+ 82h	read / write	2 Byte	Function register for channel 1, see para. 2.7
+ 84h	read / write	2 Byte	Function register for channel 2, see para. 2.7
+ 86h	read / write	2 Byte	Function register for channel 3, see para. 2.7
+ 100h	read only	2 Byte	Channel 0: Position register low-word
+ 102h	read only	2 Byte	Channel 0: Position register high-word (see 3.4)
+ 108h	read only	2 Byte	Channel 1: Position register low-word
+ 10Ah	read only	2 Byte	Channel 1: Position register high-word (see 3.4)
+ 110h	read only	2 Byte	Channel 2: Position register low-word
+ 112h	read only	2 Byte	Channel 2: Position register high-word (see 3.4)
+ 118h	read only	2 Byte	Channel 3: Position register low-word
+ 11Ah	read only	2 Byte	Channel 4: Position register high-word (see 3.4)

Register:

	D15-12	D11	D10-9	D8	D7-6	D5	D4-2	D1	D0
Command	0	0	0	1	0	Start-Bit	0	S1.8	S1.7
Acknowledgement	0	0	0	1	0	Start-Bit	0	S1.8	S1.7
Status	0	Access-Timeout (130ms)	0	1	0	0	0	S1.8	S1.7

3.1 Command Register

The following functions are implemented in the command register:

Bit No.	Description	Action	Remarks
5	Start bit	Edge 0 -> 1	Set bit 5 in the acknowledgement register

Explanations:

Bit 5 : See "start bit" (section 2.7).

SYSRESET* or power-on (UB5) resets bit 5 of the command register to 0

3.2 Acknowledgement Register

The acknowledgement register contains acknowledgement information for the following bits of the command register:

Bit No.	Description	Remarks
5	Start bit	1 = after Start bit setting 0 = after SYSRESET or power-on

3.3 Status Register

The status register of the VME4SSI contains the following messages:

Bit No.	Description	Remarks
0	Initialization	1 = Initialization underway 0 = Board initialization complete
11	VME accesses 1)	1 = VME accesses $t > 130$ ms (timeout) 0 = accesses $t < 130$ ms

1) Only applicable to accesses to the data dialog register

3.4 Data Dialog Registers

These registers permit accesses to the position registers of the transducer channels (see para. 2.6):

Base address	Description	Access	Size	Remarks
+ 100h	Position register, channel 0	read only	2 Byte	Low word
+ 102h	Position register,channel 0	read only	2 Byte	High word
+ 104h	Position register,channel 0	read only	2 Byte	Mirroring of <base address + 100
+ 106h	Position register,channel 0	read only	2 Byte	Mirroring of <base address + 102
+ 108h	Position register,channel 1	read only	2 Byte	Low word
+ 10Ah	Position registerchannel 1	read only	2 Byte	High word
+ 10Ch	Position register,channel 1	read only	2 Byte	Mirroring of <base address + 108
+ 10Eh	Position register,channel 1	read only	2 Byte	Mirroring of <base address + 10A
+ 110h	Position register,channel 2	read only	2 Byte	Low word
+ 112h	Position register,channel 2	read only	2 Byte	High word
+ 114h	Position register,channel 2	read only	2 Byte	Mirroring of <base address + 110
+ 116h	Position register,channel 2	read only	2 Byte	Mirroring of <base address + 112
+ 118h	Position register,channel 3	read only	2 Byte	Low word
+ 11Ah	Position registerchannel 3	read only	2 Byte	High word
+ 11Ch	Position register,channel 3	read only	2 Byte	Mirroring of <base address + 118
+ 11Eh	Position register,channel 3	read only	2 Byte	Mirroring of <base address + 11A

The purpose of address mirroring is to ensure that both Big-Endian and Little-Endian processors can read such double words without swapping

4 Connector Layout

- VMEbus connector layout P1 (position X1)

Pin No.	signalname		
	Row a	b	c
1	D00	BBSY	D08
2	D01	BCLR	D09
3	D02	ACFAIL	D10
4	D03	BG0IN	D11
5	D04	BG0OUT	D12
6	D05	BG1IN	D13
7	D06	BG1OUT	D14
8	D07	BG2IN	D15
9	GND	BG2OUT	GND
10	SYSCLK	BG3IN	SYSFAIL
11	GND	BG3OUT	BERR
12	DS1	BR0	SYSRESET
13	DS0	BR1	LWORD
14	WRITE	BR2	AM5
15	GND	BR3	A23
16	DTACK	AM0	A22
17	GND	AM1	A21
18	AS	AM2	A20
19	GND	AM3	A19
20	IACK	GND	A18
21	IACKIN	SERCLK(1)	A17
22	IACKOUT	SERDAT(1)	A16
23	AM4	GND	A15
24	A07	IRQ7	A14
25	A06	IRQ6	A13
26	A05	IRQ5	A12
27	A04	IRQ4	A11
28	A03	IRQ3	A10
29	A02	IRQ2	A09
30	A01	IRQ1	A08
31	-12V	+5V STDY	+12V
32	+5V	+5V	+5V

P2 is not connected

- Periphery connector layout (positions X1-X4)

The shaft-angle encoders and linear transducers are connected via 9-pin DSUB plug connectors on the front panel.

Connection	Meaning
1	US (supply voltage – not connected)
2	free
3	Data- (input)
4	Clock- (output)
5	free
6	MS (0 V – not connected)
7	free
8	Data+ (input)
9	Clock+ (output)
Enclosure	connected to front panel

X19 ^ transducer channel 0

X35 ^ transducer channel 1

X54 ^ transducer channel 2

X75 ^ transducer channel 3

Note: It is absolutely essential that the periphery is connected properly because a wrong connection of the supply voltage can lead to the destruction of the interface circuits.

Confounding of signal cables can cause loss of information

VME4SSI

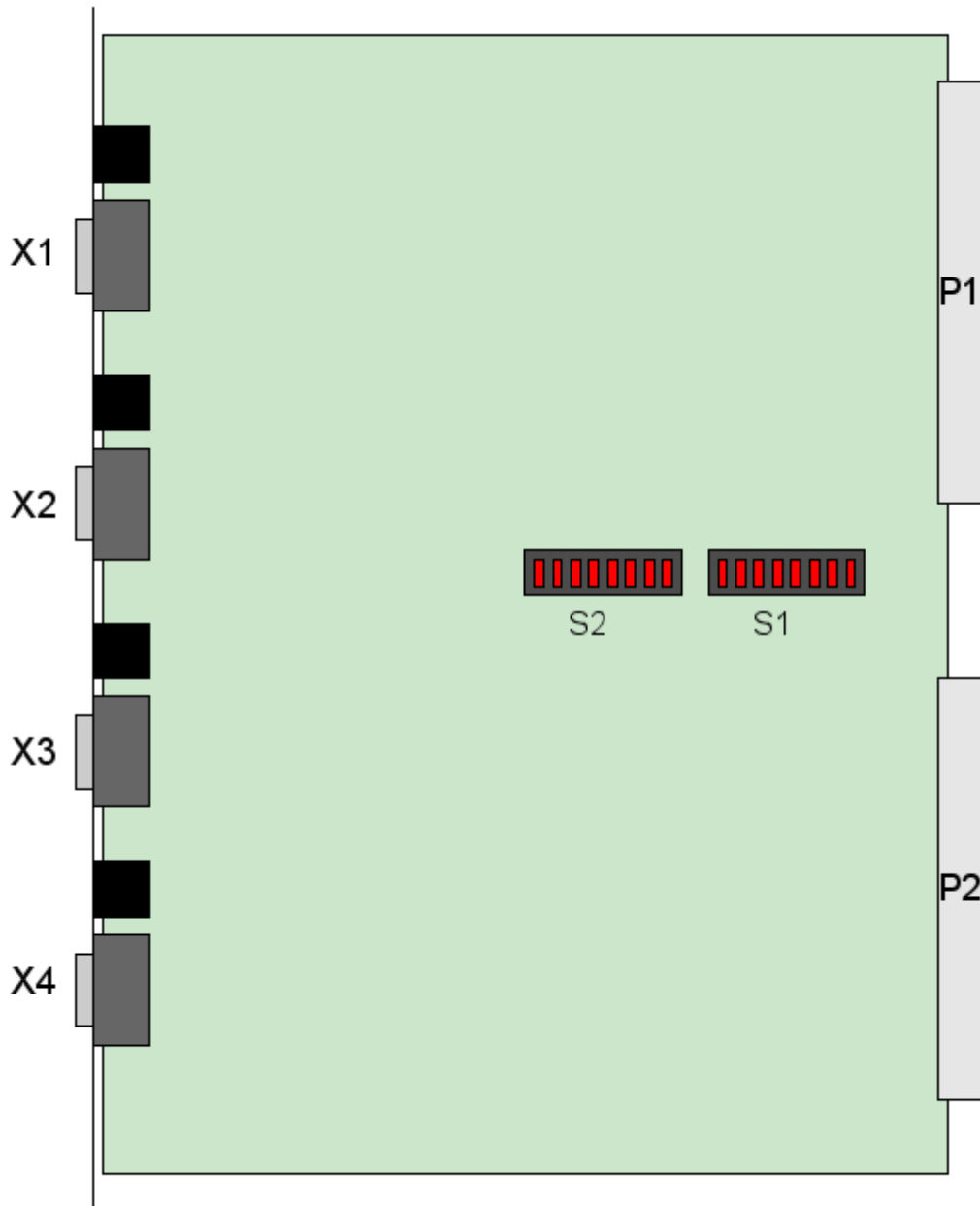

4.1 Connection Information

The connection of the transducers requires, for external wiring, cables with three twisted pairs and an overall screen, as follows:

- one twisted pair for Data + / Data --
- one twisted pair for Clock + / Clock --

The following cables are recommended:

- LifYCY 3x2 x0.20 mm 2 (manufacturer: Metrofunk)
- Unitronic-Bus FD-LD (article No. 2770215), manufacturer: Lappkabel, Stuttgart, Germany

The overall cable shield must be connected to the cubicle frame at the plug distributor with an allover contact and with a low resistance.

Note: Confounding of signal cables can cause loss of information. When engineering the VME4SSI, make sure that the clock frequency for data transmission is appropriately parametrized, depending on the length of the cable between transducer and VME4SSI. The maximum clock frequency which can be selected also depends on the capacity of the cable between transducer and VME4SSI. It must be ensured that the signal change of the transducer information takes place with a lead time of $t > 100\text{ns}$ before the next clock edge supplied by the VME4SSI.

5 Technical Specifications

POWER SUPPLY

VMEbus

UB5 = +5 V, $\pm 5\%$

I_{typ} < 500 mA

M5 = reference point (GND) for UB5

Periphery (transducer interface per channel)

Inputs (Data+ / Data-) EIA RS422 galvanically isolated against other channels and VMEbus

Insulation voltage U = 250 V AC

Outputs (Clock + / Clock-) EIA RS422 potential-isolated against other channels and VMEbus

Insulation voltage U = 250 V AC

AMBIENT CONDITIONS

Ambient temperature 0°C to +50°C (with natural convection)

Storage temperature -40°C to +80°C

Humidity class F

ELECTROMAGNETIC COMPATIBILITY

- Norm (pr) EN 50081-2 for interference emission

- Norm (pr) EN 50082-2 for interference immunity

MECHANICAL DESIGN

- **Format** double Euro

Dimensions approx. 233.4 mm x 160 mm x 20.5 mm (H x D x W)

- **Connectors**

VMEbus P1 E96M-C1A

VMEbus P2 E64M-C1A

Periphery 9-pin DSUB connectors (X1-X4)

Weight approx. 400G