

2.92mm/2.92mm

DC - 40GHz, Coaxial Panel Adapters For Front Access Ports

DESCRIPTION

This "KPC292MF FPA" called coaxial front panel adapter that easy to mate, good return loss and low insertin loss, are designed for frequently connect/disconnect accessed broadband measurement, instrument and system use.

SPECIFICATIONS:

Electrical:

Frequency Range DC - 40 GHz
 Return Loss Better than 26 dB
 Insertion Loss <0.3 dB
 Electrical Length Below (Nominal)
 Temperature Range -55 to +125 deg.C

Mechanical:

Body: Passivated Stainless steel (*)
 Outer Conductors: Gold Plated Stainless steel
 Inner Conductors: Gold Plated Beryllium Copper
 Coupling Torque 90 N-cm(Nominal)
 Connect/Disconnect Life >1,000 Cycles



Production Status
 Three weeks Lead-Time will be available for shipping.

TYPE: KPC292MF FPA 2.92mm Male/2.92mm Female

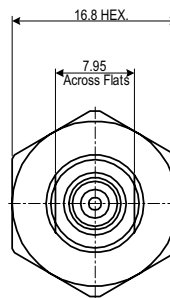
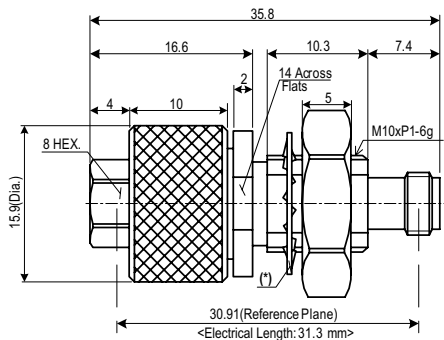

Mounting Hole and Thickness (Recommended)



Thickness: 2 to 5.4mm

Typical Performance

No. of Samples: 7 pcs

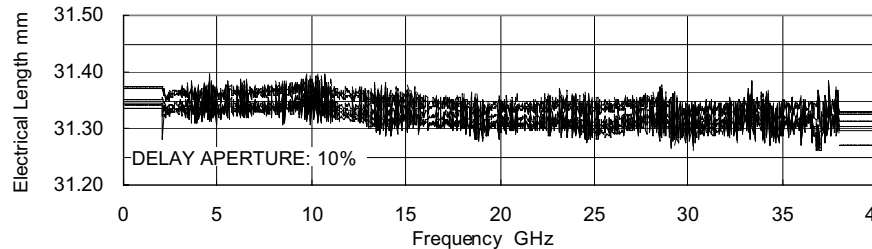
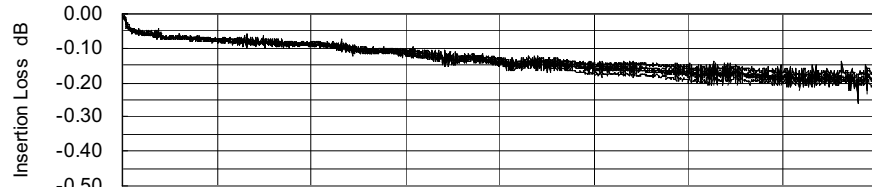
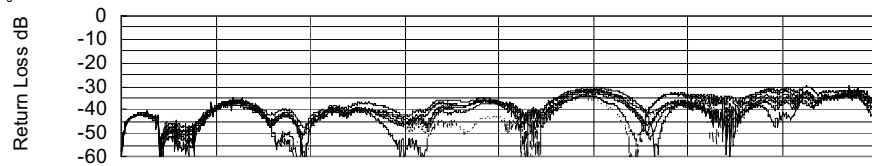

Interface Mating Dimensions of KPC292 (2.92mm Connectors)

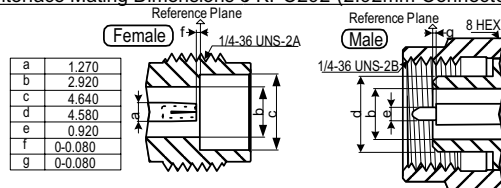

a	1.270
b	2.920
c	4.640
d	4.580
e	0.920
f	0-0.080
g	0-0.080

<*> Matable with 3.5mm and SMA

Note:
 - All dimensions are in Millimeters.
 - (*)The toothed lockwasher is nickel plated steel.

Specifications Subject to Change Without Notice.

Copyright(C) 2002-2007 KAWASHIMA Mfg. Co., Ltd. All rights reserved.

292MF FPA Rev.00 JLY.2007



Kawashima Manufacturing Co., Ltd.

1-3-5 Higashiikuta, Tama-ku,
 Kawasaki 214-0031 JAPAN

TEL: +81-44-911-7073
 http://www.kmco.biz/

FAX: +81-44-911-9621
 e-mail: sales @kmco.co.jp